

# Specification of Manganese Batteries

**type : UM-5**

**Issued : 01. Apr. 1999**

**SANYO Electric Co., Ltd.**  
**Soft Energy Business Headquarters**  
Overseas Sales Dept.  
(TEL : ++81-6-6900-3775)  
(FAX : ++81-6-6901-7797)

1. Scope : This specification is applicable to the following Dry Batteries Supplied to SANYO Energy (Europe) Corporate GmbH from SANYO Electric Co., Ltd.

- 2. Type : UM-5
- 3. Nominal Voltage : 1.5V
- 4. Figure and Dimensions : See Fig. 1
- 5. Standard Weight : 7g
- 6. Terminals : + : Cap Terminal, - : Base Terminal

7. Quality Characteristics

- 7.1 Dimensions : Dimensions are shown in Fig. 1.
- 7.2 Terminal : There shall be no rust or deformation that occurs troubles practically.
- 7.3 Appearance : There shall be no rust, deformation or scratch that occurs troubles practically.
- 7.4 Electrical Characteristics

( Table 1 )

Item		Requirement		Test Conditions
Open-Circuit Voltage (V)		Initial	1.52 - 1.72	Temp. : 20 +/- 2 centigrade RH : 65 +/- 20%
		After 2 years	1.50 - 1.72	
Service Life (H)	Discharge at 15 ohm	Initial	Over 3.0	Temp. : 20 +/- 2 centigrade RH : 65 +/- 20% End Voltage : 0.85V Daily period : 10min
		After 2 years	Over 2.0	

8. Test

8.1 Storage and Test Conditions

(1) Storage Condition

Unless otherwise specified, storage condition shall be kept at 20 +/- 2 centigrade and at 65 +/- 20%RH.

(2) Test Condition

Unless otherwise specified, test shall be conducted at 20 +/- 15 centigrade and at 65 +/- 20%RH.

8.2 Instruments and Devices

(1) Voltmeters

The voltmeters shall be of Class 0.5 or better specified in JIS C1102 (Electrical Indicating Instruments) and shall have a internal resistance not less than 1,000 ohm/V. But voltmeters for service life test shall have a internal resistance not less than 1,000 ohm/V or not less than 10 times of load resistance, which ever is larger.

(2) Load Resistance

The load resistance shall include all resistances in external circuit, and its tolerance shall be +/-



0.5%.



Spec9901ce

(3) Calipers

Calipers shall be type M, Grade 1 as specified in the JIS B7507 or those having equal or better precision.

8.3 Test Methods

(1) Dimensions

Measurement shall be made with calipers or measuring device having equal or better precision specified in 8.2 (3).

(2) Terminals

Visually.

(3) Appearance

Visually.

(4) Open-Circuit Voltage

Shall be measured with a volt meter specified in 8.2 (1), after the batteries have been leaving at 20 +/- 2 centigrade for 8 hours minimum.

(5) Closed-Circuit Voltage

Shall be measured with a volt meter specified in 8.2 (1), under the load specified in table 1, after the batteries have been leaving at 20 +/- 2 centigrade for 8 hours minimum.

(6) Service Life

The test batteries shall be stored at 20 +/- 2 centigrade and 65 +/- 20% RH, for 8 hours minimum and then shall be discharged continuously as specified in table 1.

9. Quality Incoming Inspection

9.1 Inspection item and its method

Inspection shall be done by normal sampling plan as per MIL STD 105D, unless it is specified.

The criterion shall be shown in Table 2.

( Table 2 )

NO	Tests		Inspection Level	A.Q.L. (%)
1	Open Circuit Voltage		II	0.15
2	Duration Time		n=5	C=0
3	Dimensions		S-4	0.65
4	Appearance	Major	II	0.15
		Minor	II	1.0

• Remarks

MAJOR DEFECT : Leakage  
 Mistake on Brand  
 Rusting or Corroded  
 Excessive Tool Marks



MINOR DEFECT : Scratches  
Poor Graphics  
Indistinct Marking

9.2 Inspection Lot

One lot of supply to be a inspection lot.

9.3 The starting time of inspection

The inspection shall be started within one month after the supply.

(Fig.1)

UM-5 Dimension Drawing

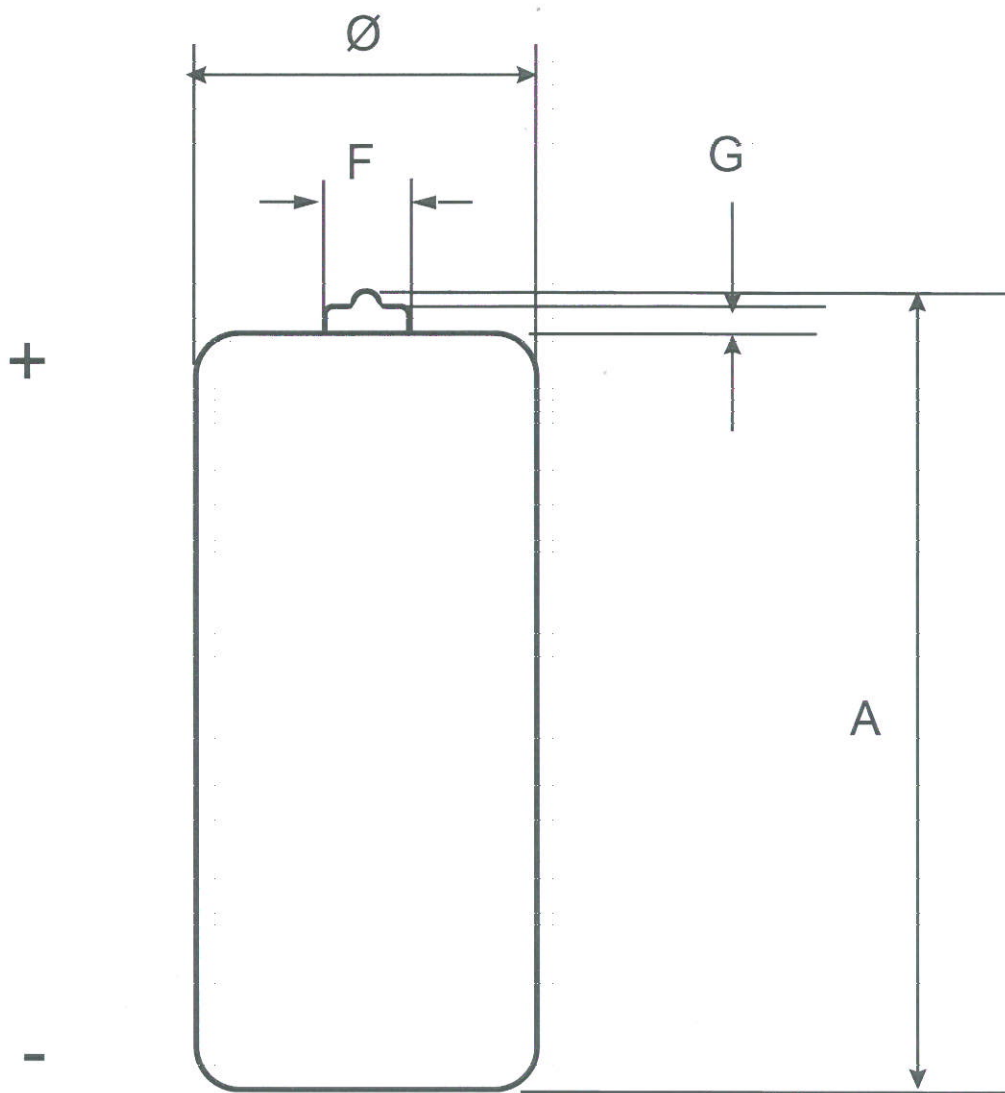

Sign	Dimension
$\varnothing$	10.7 - 12.0
A	28.0 - 30.2
F	2.0 - 4.5
G	MIN 0.3

Unit : mm

Terminal : + : Cap Terminal

- : Base Terminal

(Remarks)

This battery uses an expiry date code (two years)

instead of a manufacturing date code.

Example : 07-02

month - Christian Era