



Poly carbonmonofluoride (BR series) /manganese dioxide (CR series) lithium batteries

Overview

The Panasonic coin type lithium primary battery is a high-energy, high-density battery resulting from our extensive experience in battery technology. Provided with outstanding features, which conventional dry batteries cannot attain, this battery has a broad range of applications, such as the main power supply of clocks/watches and electronic notebooks, and the memory backup power supply for C-MOS RAM memories and microcomputer IC memories.

Panasonic meets different market needs with two types (30 sizes) of the product offering a wide capacity range (18mAh to 1000mAh): poly carbonmonofluoride lithium batteries (BR series) which exhibit stable performance at comparatively high environment temperatures, and manganese dioxide lithium batteries (CR series) which show excellence in comparatively large current applications like the alarm actuation in watches.

Features

- **Voltage about twice that of dry batteries**
The nominal voltage is as high as 3 V, approximately twice that of manganese and alkaline button batteries. A single lithium battery can replace two or three conventional batteries.
- **Excellent storability with minimal deterioration**
Minimal deterioration is not necessarily an inherent feature of lithium batteries. It is achieved by using chemically stable materials and superior production methodologies and sealing techniques. Panasonic coin type lithium batteries show an annual deterioration rate as low as about 1.0% at room temperature, meeting the requirement for a room-temperature storage period of more than 10 years.
- **Wide operating temperature range (-40°C to 85°C)**
Organic solvents are used for the electrolyte in lithium batteries. Therefore, the solidifying point of

- this electrolyte is much lower than that of the aqueous solution type electrolyte in manganese batteries, etc., enabling the use of lithium batteries in low-temperature regions. Panasonic coin type lithium batteries are mostly operable over the temperature range from -40°C to 85°C.
- **Strong leakage resistance**
The organic electrolyte liquid used in lithium batteries shows minimal creep. This feature, and our unique sealing technique, give our batteries very strong leakage resistance.
- **UL-recognized product**
Panasonic coin type lithium batteries have all acquired the component recognition of UL (Underwriters Laboratories Inc.) in U.S..(File No. MH12210)

Poly carbonmonofluoride (BR series) lithium batteries

Model No.	JIS	IEC	Electrical characteristics 20°C			Dimensions (Max.)		Approx. weight (g)
			Nominal voltage (V)	Nominal capacity *1 (mAh)	Continuous drain	Diameter (mm)	Height (mm)	
					Standard (mA)			
BR1216	---	---	3	25	0.03	12.5	1.60	0.6
BR1220	---	---	3	35	0.03	12.5	2.00	0.7
BR1225	---	BR1225	3	48	0.03	12.5	2.50	0.8
BR1616	---	---	3	48	0.03	16.0	1.60	1.0
BR1632	---	---	3	120	0.03	16.0	3.20	1.5
BR2016	---	BR2016	3	75	0.03	20.0	1.60	1.5
BR2020	---	BR2020	3	100	0.03	20.0	2.00	2.0
BR2032	---	---	3	190	0.03	20.0	3.20	2.5
BR2320	---	BR2320	3	110	0.03	23.0	2.00	2.5
BR2325	---	BR2325	3	165	0.03	23.0	2.50	3.2
BR2330	---	---	3	255	0.03	23.0	3.00	3.2
BR3032	---	BR3032	3	500	0.03	30.0	3.20	5.5

* 1 Nominal capacity shown above is based on standard drain and cut off voltage down to 2.0 V at 20°C

Manganese dioxide (CR series) lithium batteries

Model No.	JIS	IEC	Electrical characteristics 20°C			Dimensions (Max.)		Approx. weight (g)
			Nominal voltage (V)	Nominal capacity *1 (mAh)	Continuous drain	Diameter (mm)	Height (mm)	
					Standard (mA)			
CR1025	CR1025	CR1025	3	30	0.10	10.0	2.50	0.7
CR1212 *2	---	---	3	18	0.10	12.5	1.20	0.5
CR1216	CR1216	CR1216	3	25	0.10	12.5	1.60	0.7
CR1220	CR1220	CR1220	3	35	0.10	12.5	2.00	1.2
CR1612	---	---	3	40	0.10	16.0	1.20	0.8
CR1616	CR1616	CR1616	3	55	0.10	16.0	1.60	1.2
CR1620	---	CR1620	3	75	0.10	16.0	2.00	1.3
CR1632	---	---	3	125	0.10	16.0	3.20	1.8
CR2012	CR2012	CR2012	3	55	0.10	20.0	1.20	1.4
CR2016	CR2016	CR2016	3	90	0.10	20.0	1.60	1.6
CR2025	CR2025	CR2025	3	165	0.20	20.0	2.50	2.5
CR2032	CR2032	CR2032	3	220	0.20	20.0	3.20	3.1
CR2320	CR2320	CR2320	3	130	0.20	23.0	2.00	3.0
CR2330	CR2330	CR2330	3	265	0.20	23.0	3.00	4.0
CR2354	---	CR2354	3	560	0.20	23.0	5.40	5.9
CR2412	---	---	3	100	0.20	24.5	1.20	2.0
CR2477	---	---	3	1000	0.20	24.5	7.70	10.5
CR3032	---	CR3032	3	500	0.20	30.0	3.20	7.1

* 1 Nominal capacity shown above is based on standard drain and cut off voltage down to 2.0 V at 20°C

* 2 Under Development

Applications

- Electronic watches (digital and analog)
- Memory backup for all types of devices (with tab terminal)
- Calculators, cameras, and electronic notebooks
- Electronic clinical thermometers
- Other compact, low power cordless equipment

Cutaway view (BR type)

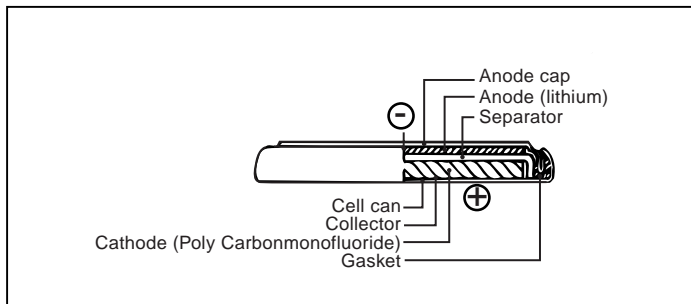

Coin type lithium batteries: size and model number

Diameter mm	30	24.5	23	20	16	12.5	10
Height mm							
7.7		CR2477					
5.4			CR2354				
3.2	BR3032 CR3032			BR2032 CR2032	BR1632 CR1632		
3.0			BR2330 CR2330				
2.5			BR2325	CR2025		BR1225	CR1025
2.0			BR2320 CR2320	BR2020	CR1620	BR1220 CR1220	
1.6				BR2016 CR2016	BR1616 CR1616	BR1216 CR1216	
1.2		CR2412		CR2012	CR1612	Δ CR1212	

Δ Under development

Characteristics

Shelf life (BR series)

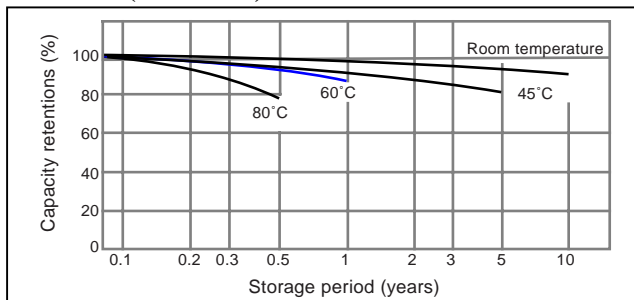

Storage characteristics (BR2325)

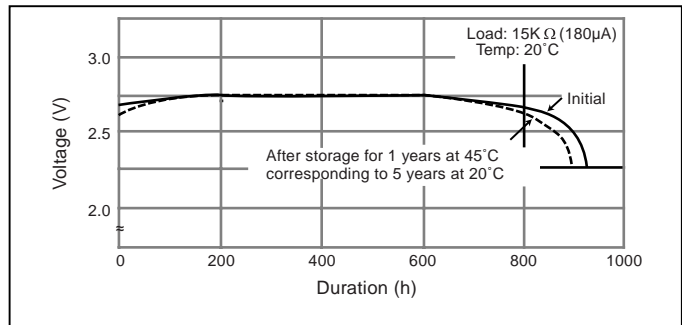
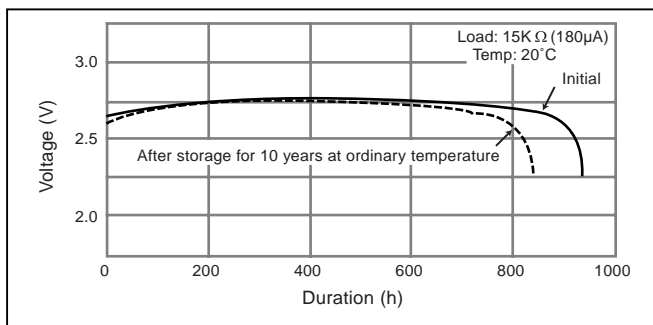

temp: 20 °C
Cut off voltage: 2.0V

Discharge life as a function of operating current

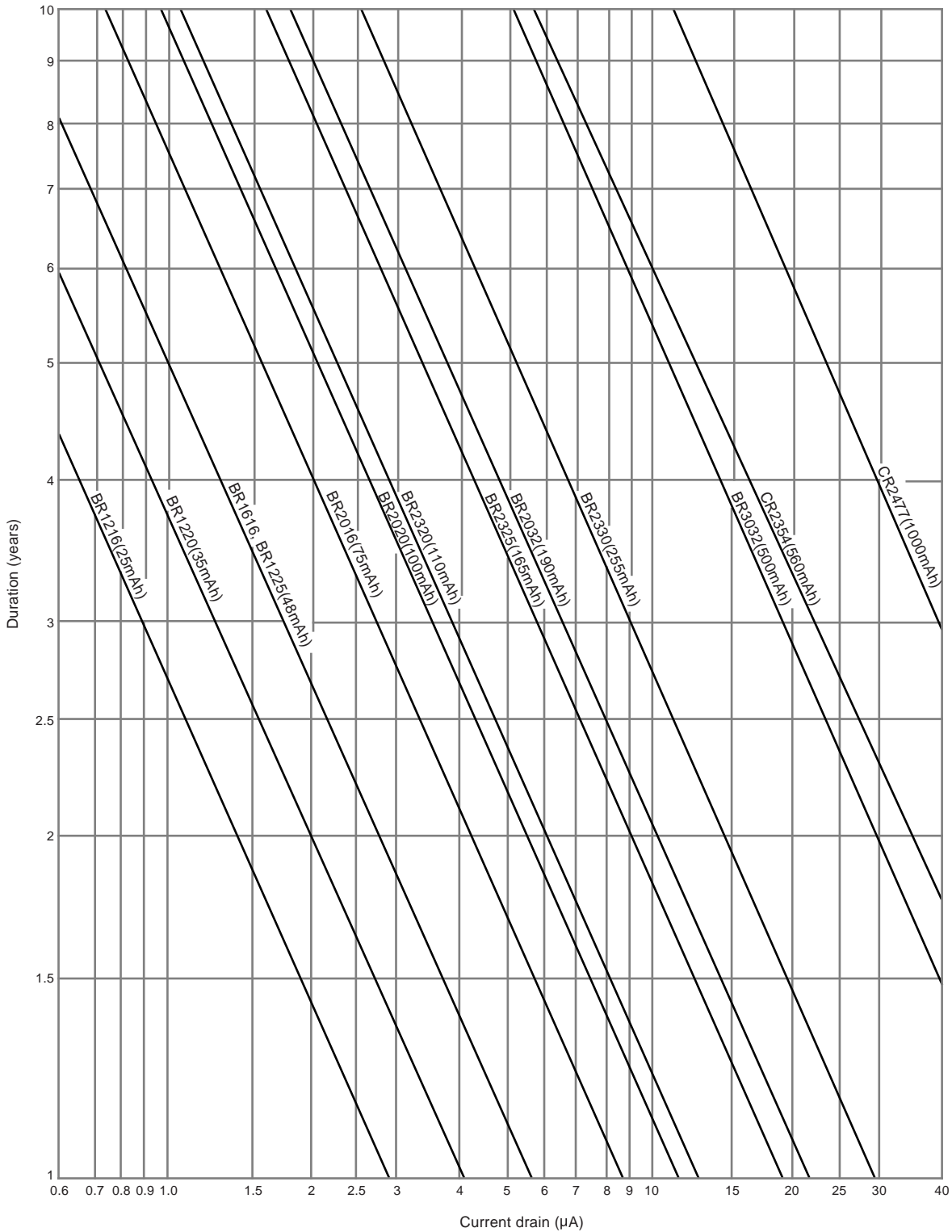

Formula:

$$\text{Duration (years)} = \frac{\text{Nominal capacity (mAh)}}{\text{Current drain (mA)} \times 24 \text{ (hours)} \times 365 \text{ (days)}}$$

DIMENSIONS (MM)

The dimension data with no tolerance indicated are standard reference values.

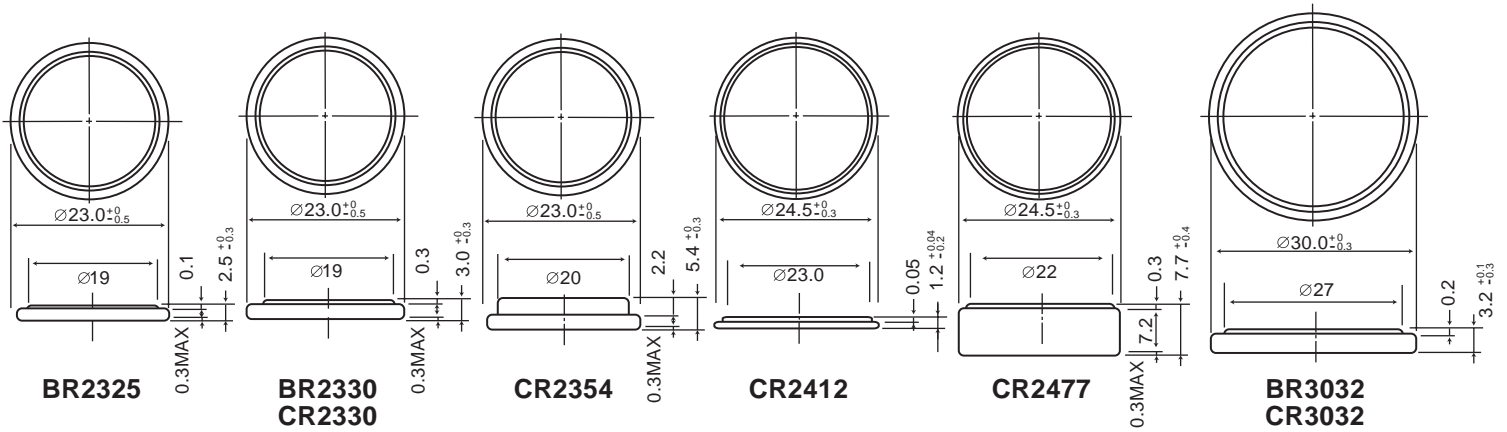
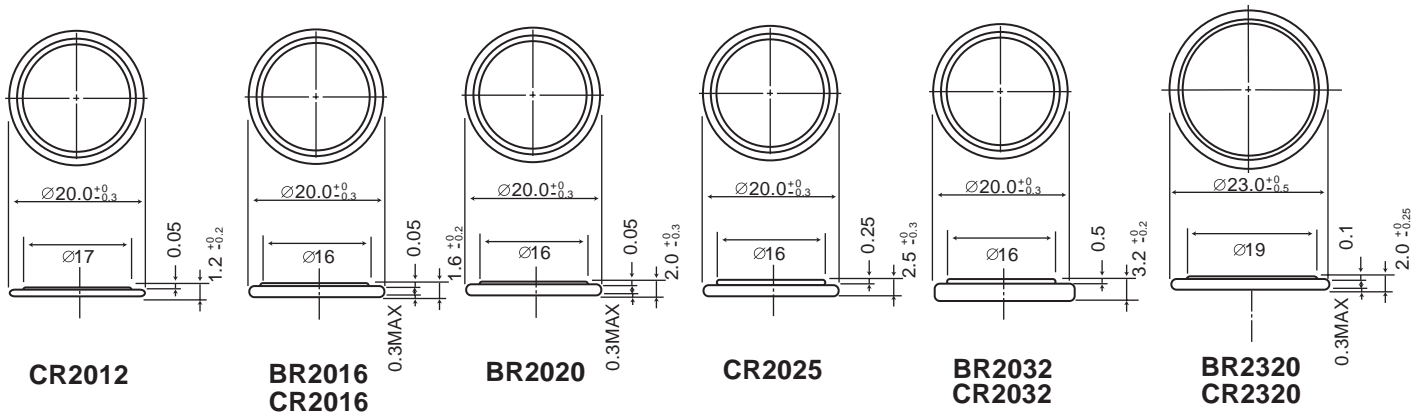
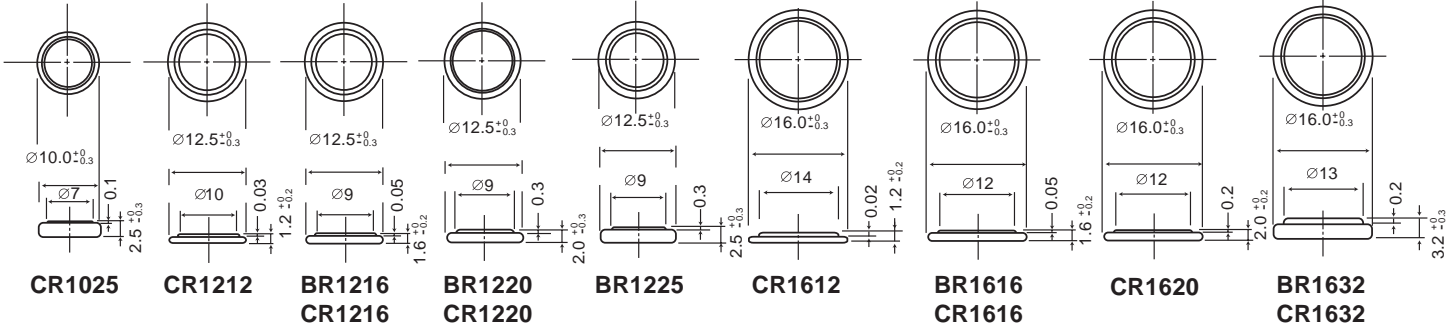
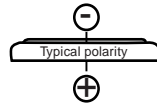

BR1216

BR1220

Discharge temperature characteristics

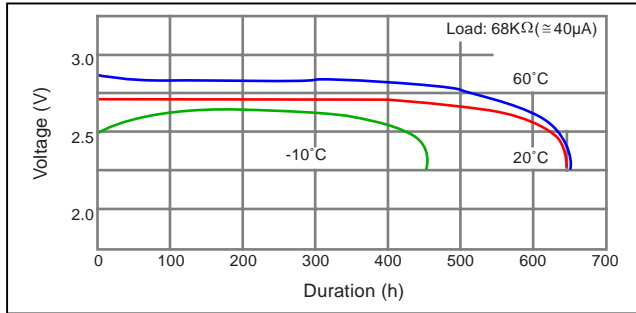

Discharge temperature characteristics

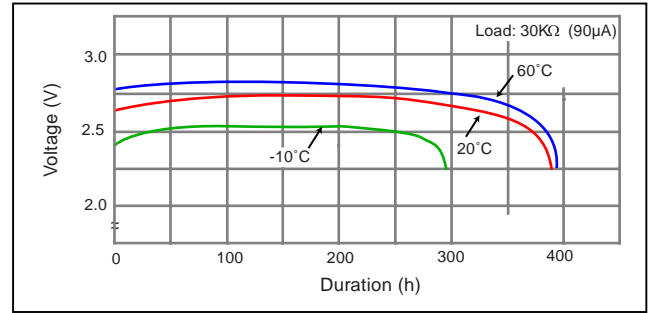

Operating voltage vs. load resistance

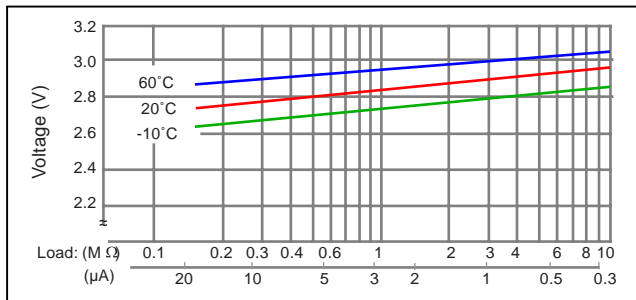

Operating voltage vs. load resistance

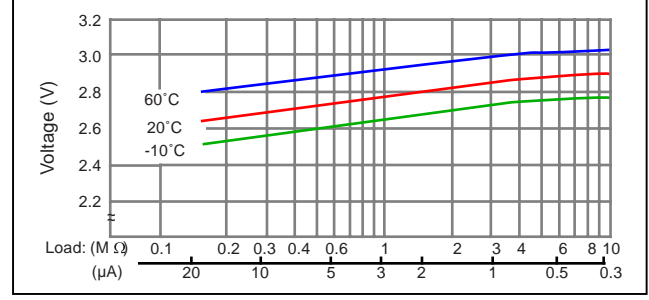

Capacity vs. load resistance

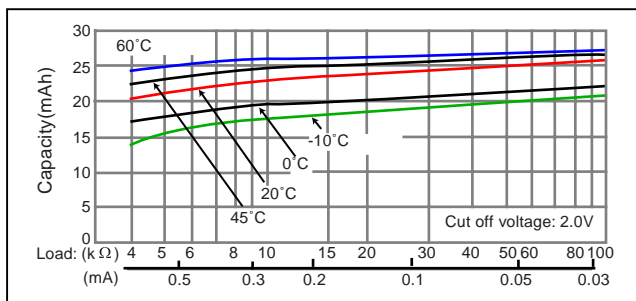

Capacity vs. load resistance

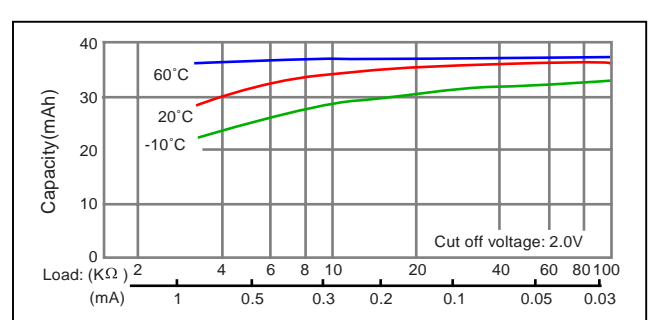

BR1225

BR1616

Discharge temperature characteristics

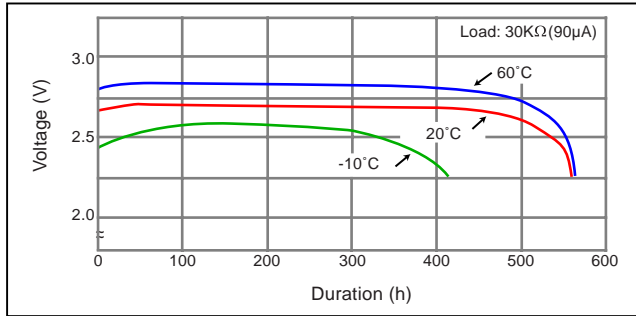

Discharge temperature characteristics

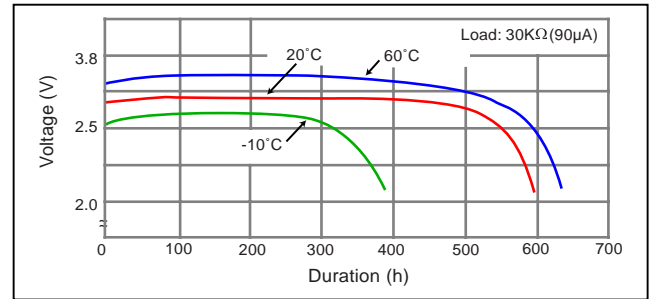

Operating voltage vs. load resistance

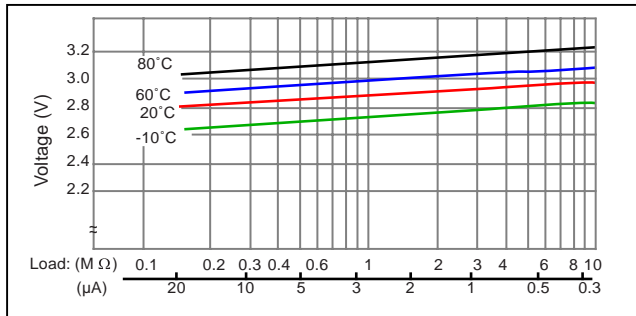

Operating voltage vs. load resistance

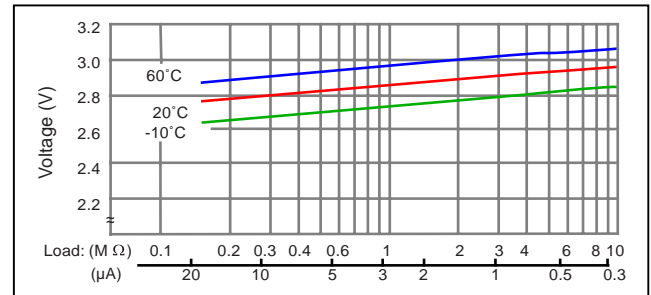

Capacity vs. load resistance

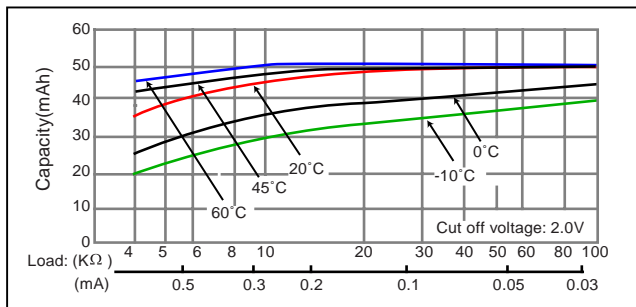

Capacity vs. load resistance

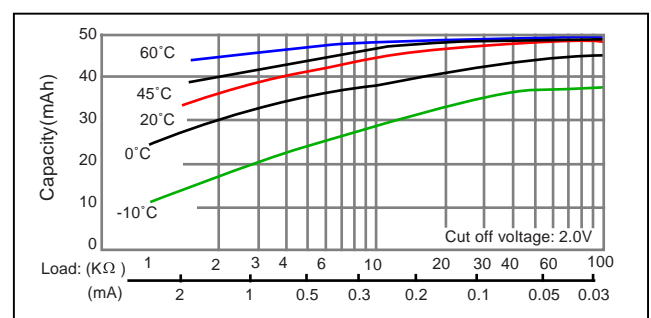

BR1632

BR2016

Discharge temperature characteristics

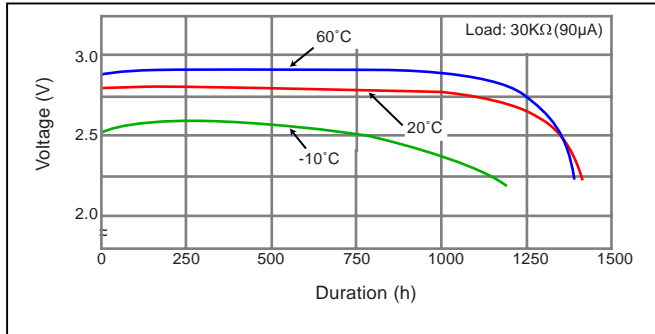

Discharge temperature characteristics

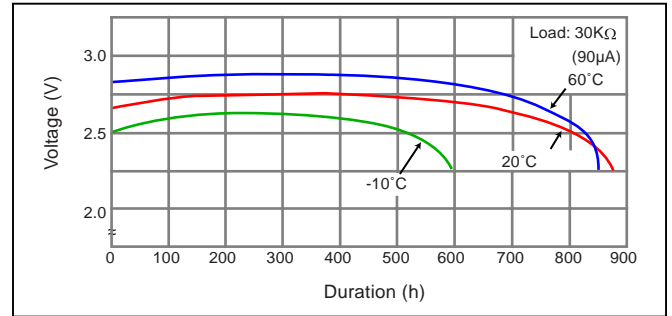

Operating voltage vs. load resistance

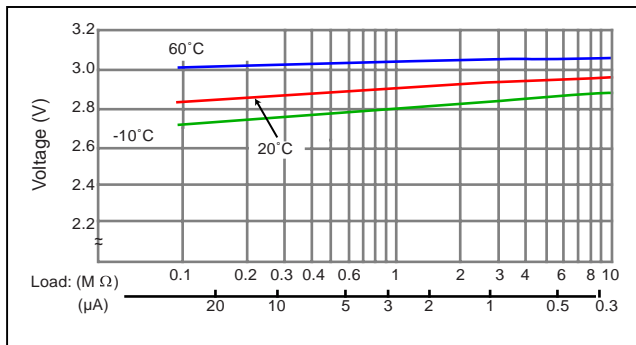

Operating voltage vs. load resistance

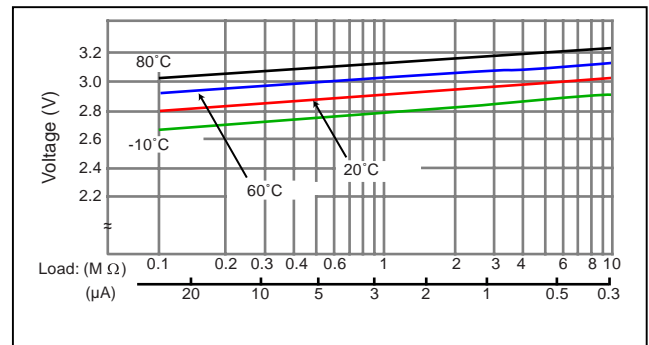

Capacity vs. load resistance

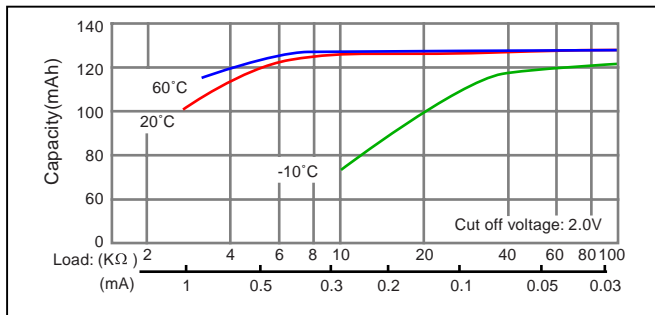

Capacity vs. load resistance

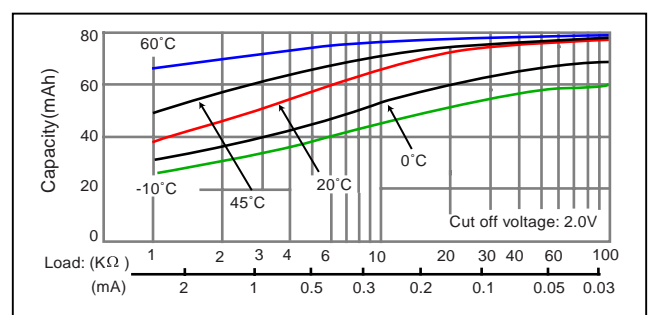

BR2020

BR2032

Discharge temperature characteristics

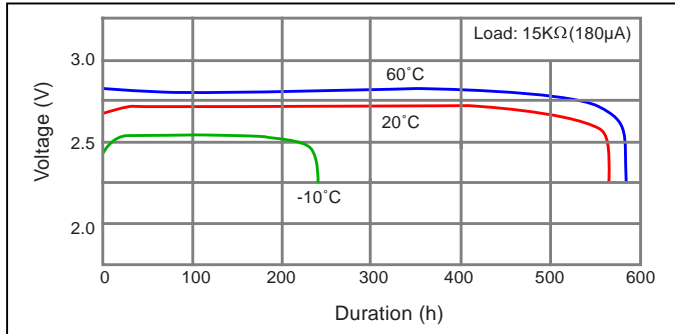

Discharge temperature characteristics

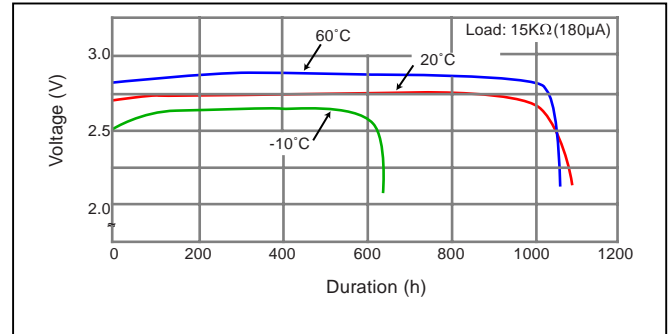

Operating voltage vs. load resistance

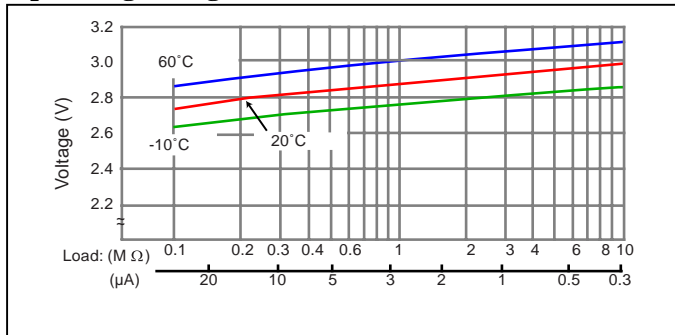

Operating voltage vs. load resistance

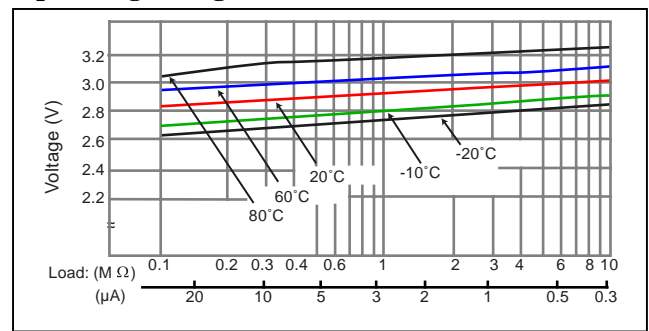

Capacity vs. load resistance

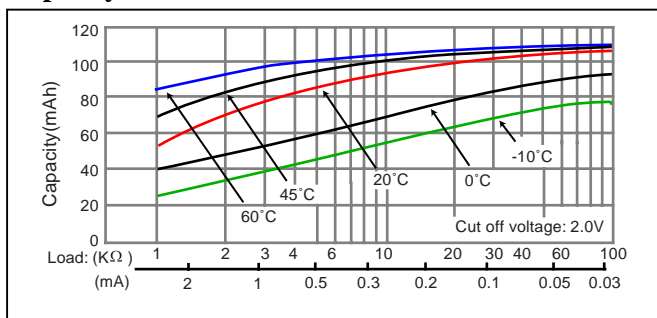

Capacity vs. load resistance

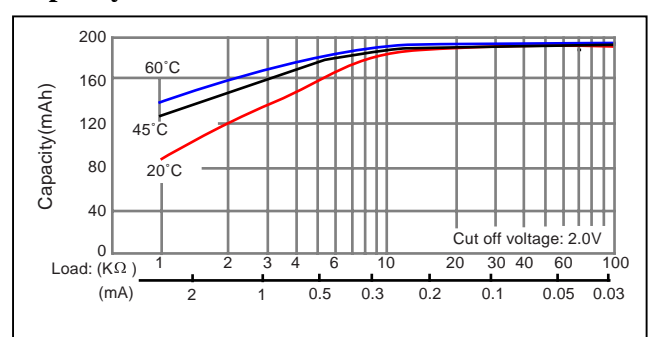

BR2320

BR2325

Discharge temperature characteristics

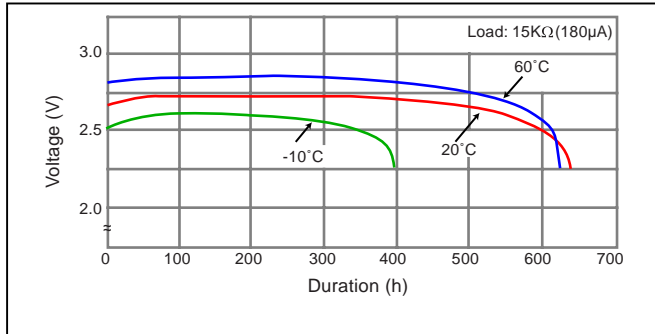

Discharge temperature characteristics

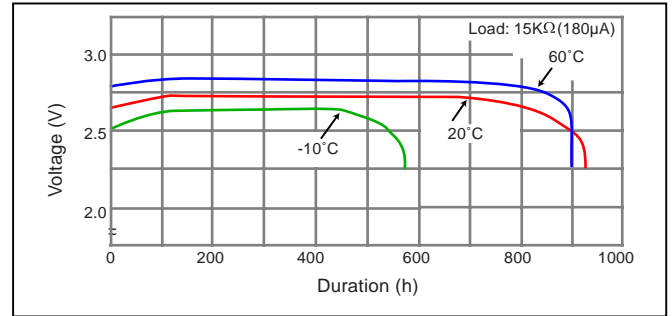

Operating voltage vs. load resistance

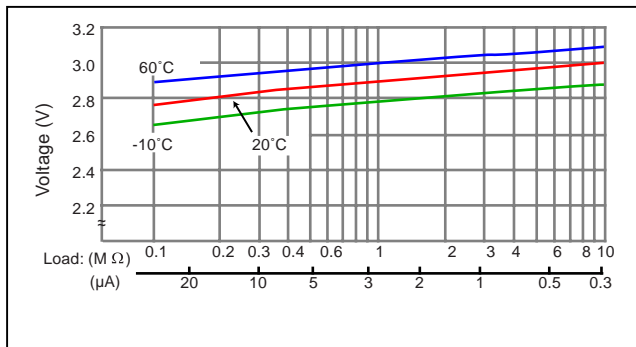

Operating voltage vs. load resistance

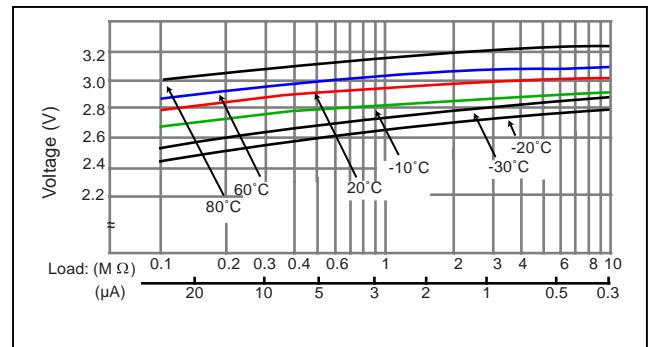

Capacity vs. load resistance

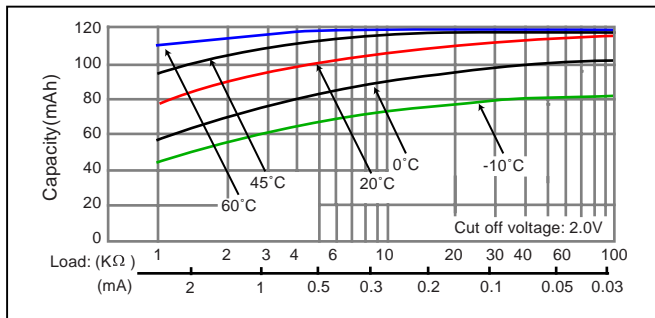

Capacity vs. load resistance

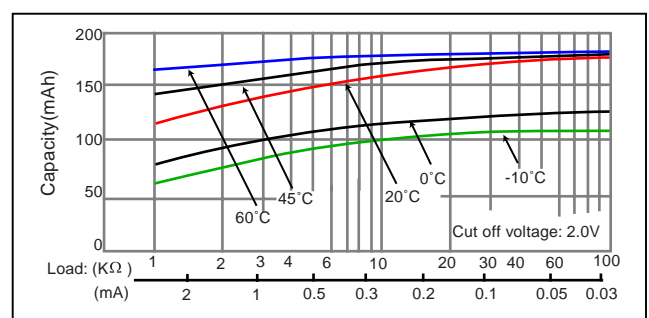

BR2330

BR3032

Discharge temperature characteristics

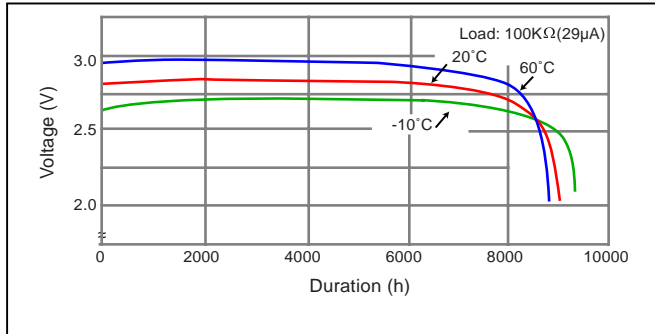

Discharge temperature characteristics

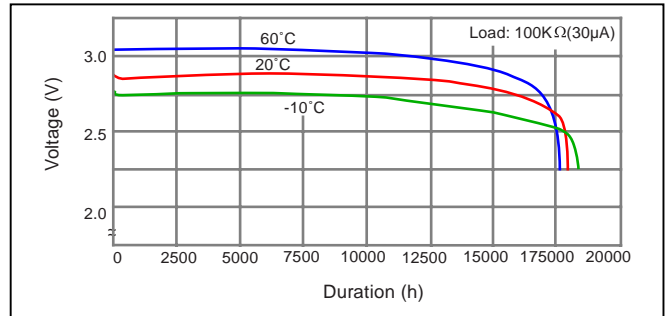

Operating voltage vs. load resistance

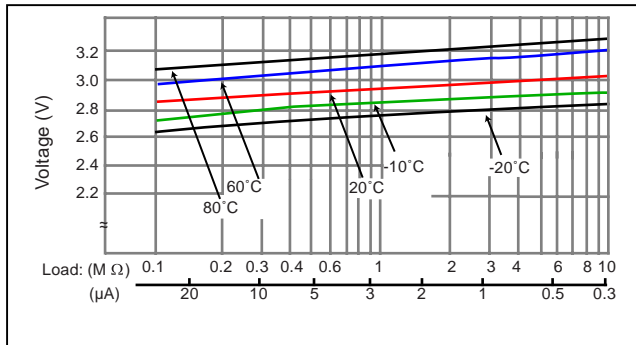

Operating voltage vs. load resistance

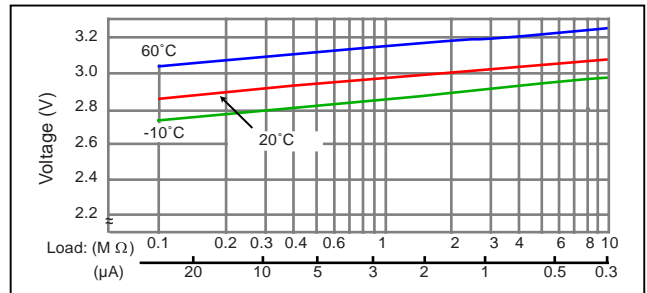

Capacity vs. load resistance

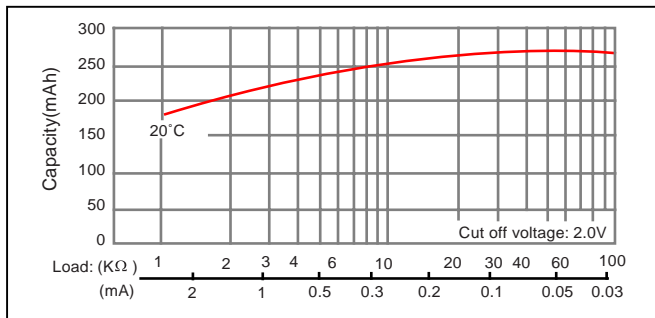

Capacity vs. load resistance

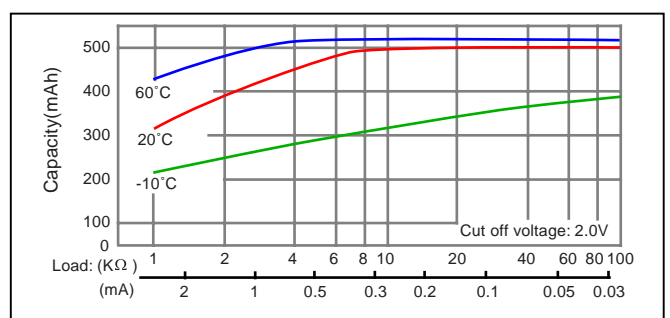

CR1025

CR1212

Discharge temperature characteristics

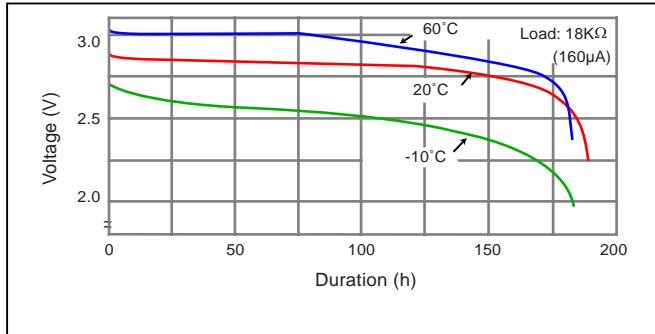

Discharge temperature characteristics

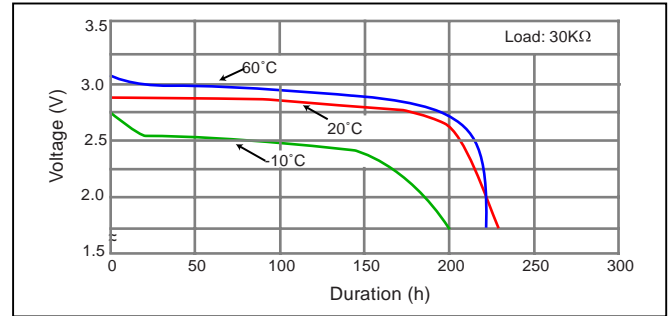

Operating voltage vs. load resistance

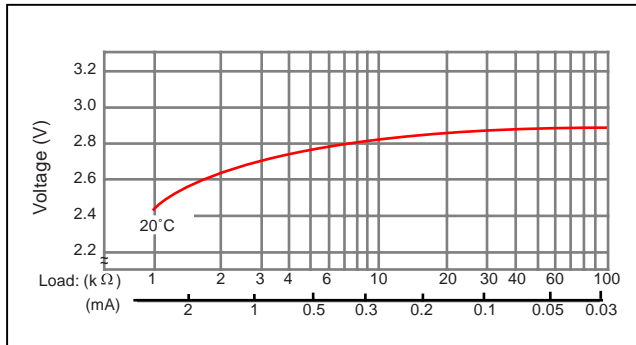

Operating voltage vs. load resistance

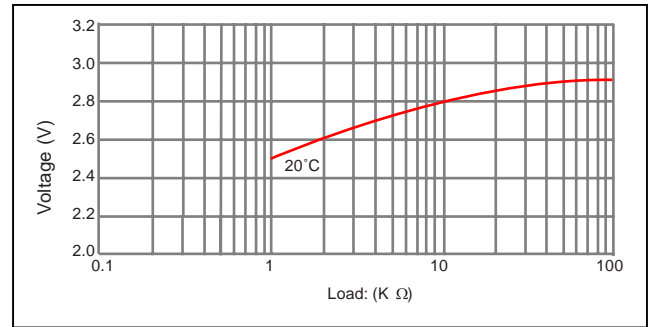

Capacity vs. load resistance

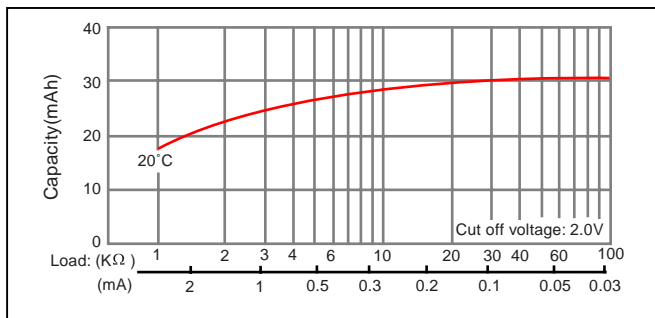

Capacity vs. load

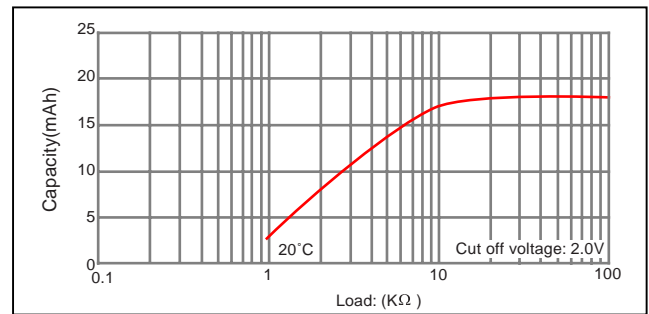

CR1216

CR1220

Discharge temperature characteristics

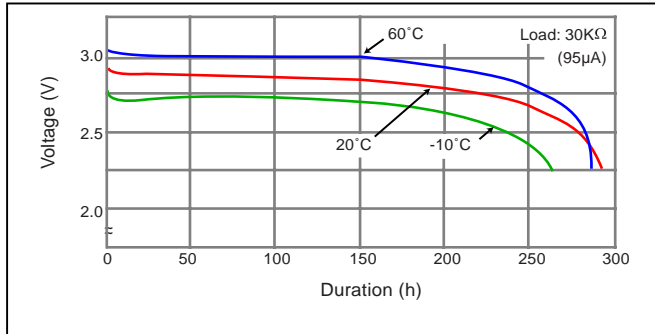

Discharge temperature characteristics

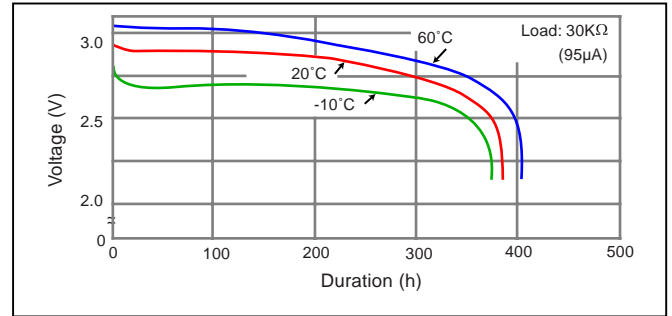

Operating voltage vs. load resistance

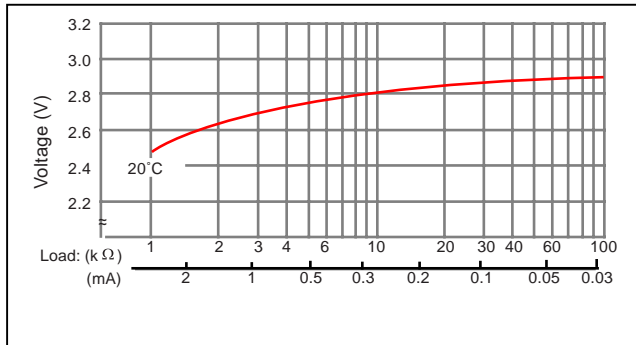

Operating voltage vs. load resistance

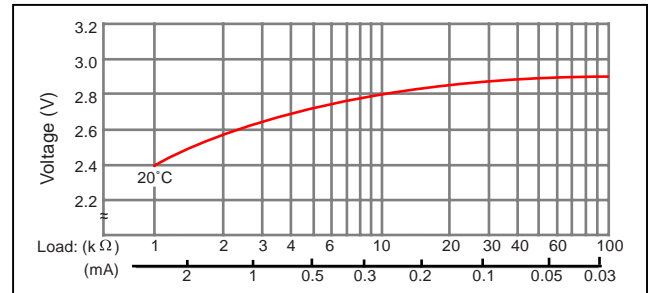

Capacity vs. load resistance

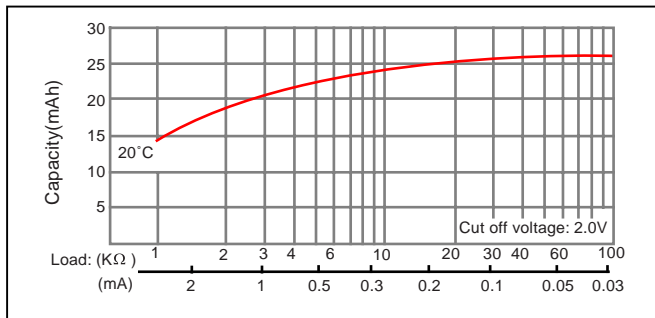

Capacity vs. load resistance

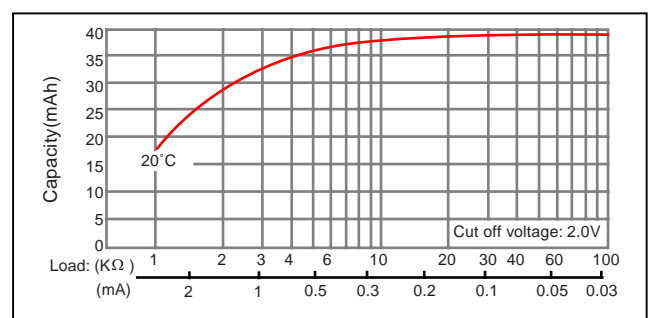

CR1612

Discharge temperature characteristics

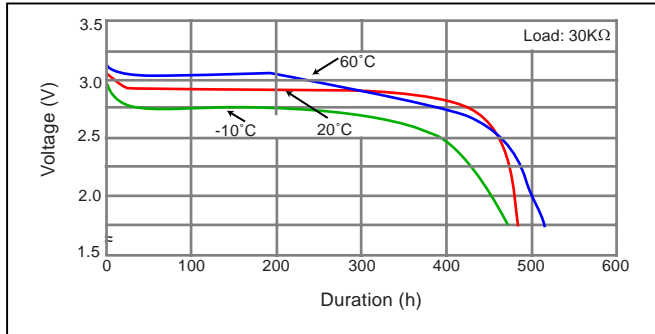

CR1616

Discharge temperature characteristics

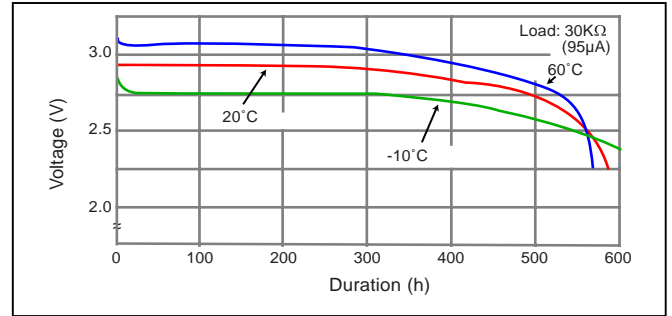

Operating voltage vs. load resistance

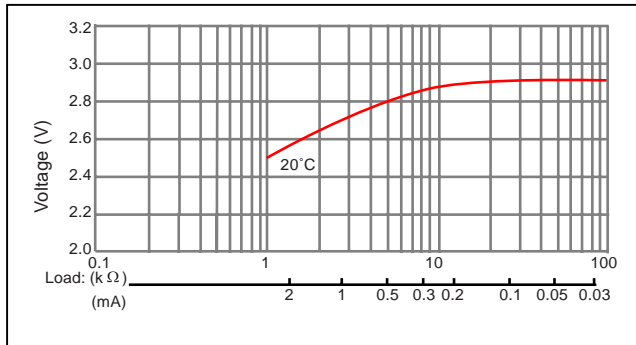

Operating voltage vs. load resistance

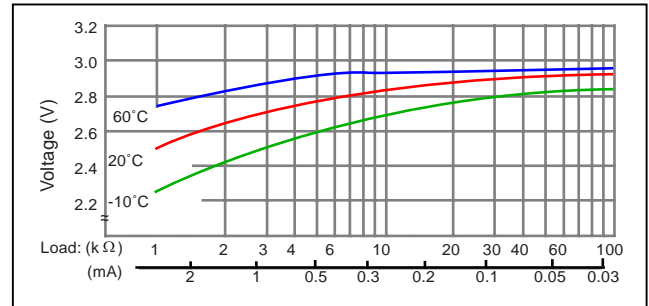

Capacity vs. load resistance

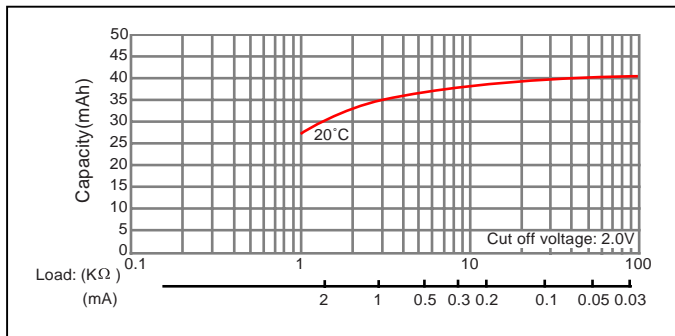

Capacity vs. load resistance

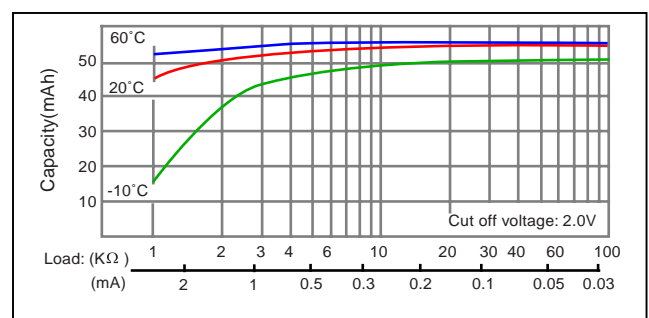

CR1620

CR1632

Discharge temperature characteristics

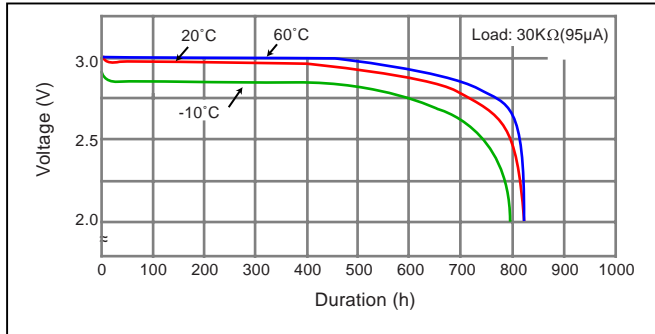

Discharge temperature characteristics

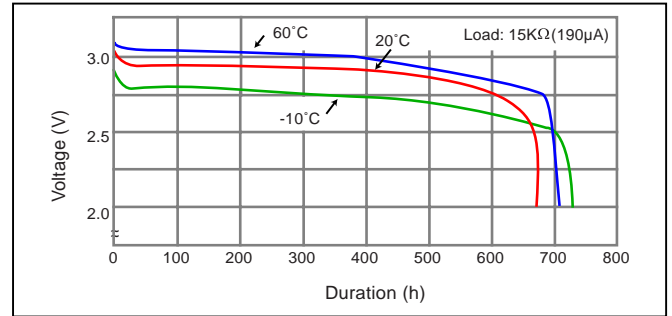

Operating voltage vs. load resistance

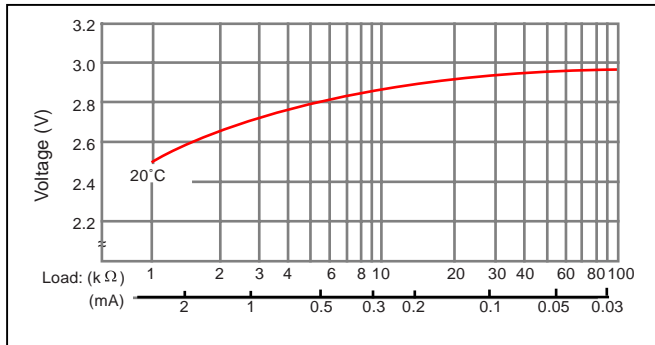

Operating voltage vs. load resistance

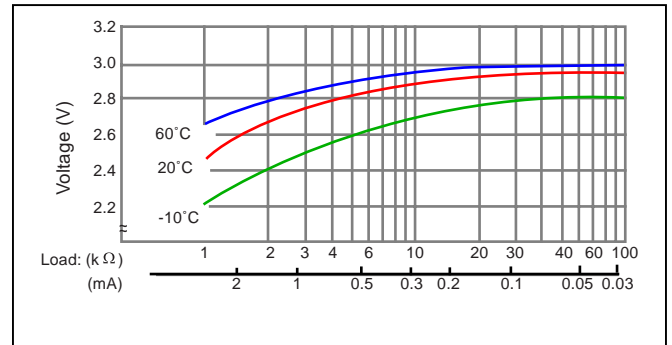

Capacity vs. load resistance

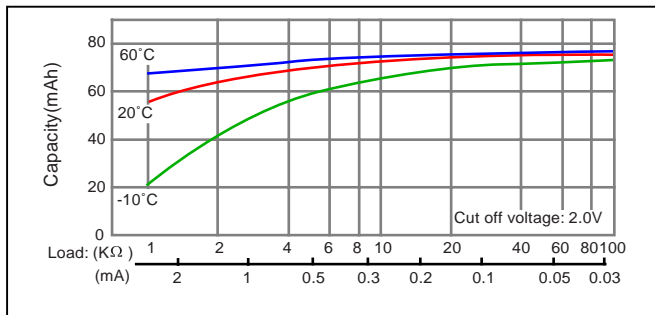

Capacity vs. load resistance

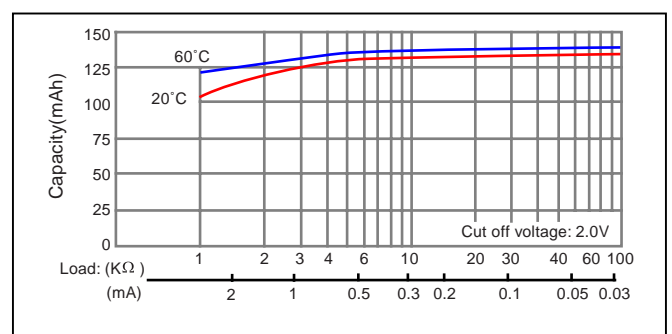

CR2012

CR2016

Discharge temperature characteristics

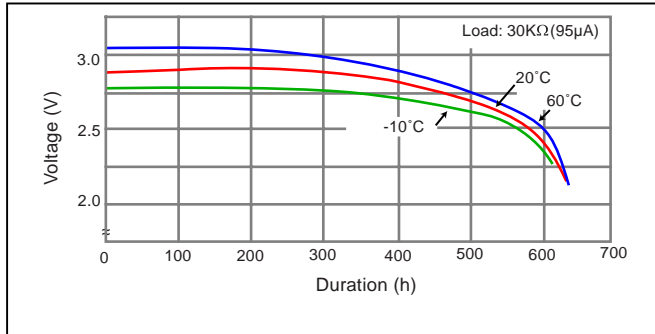

Discharge temperature characteristics

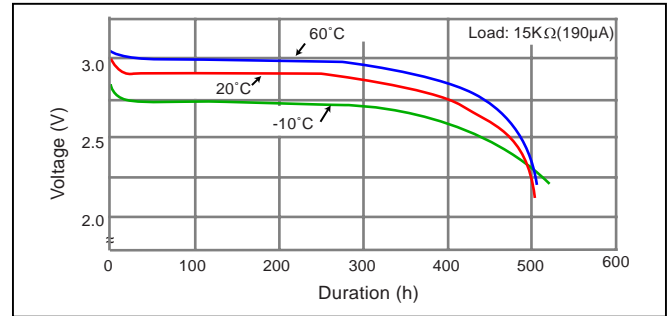

Operating voltage vs. load resistance

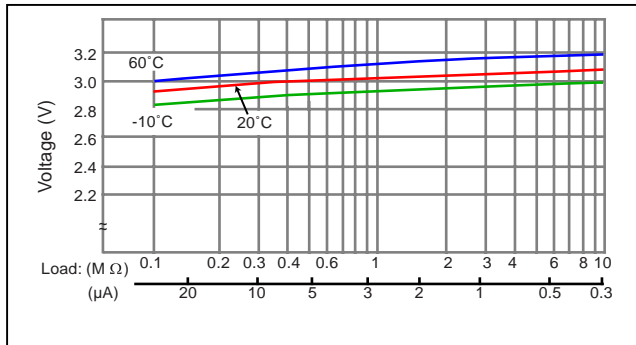

Operating voltage vs. load resistance

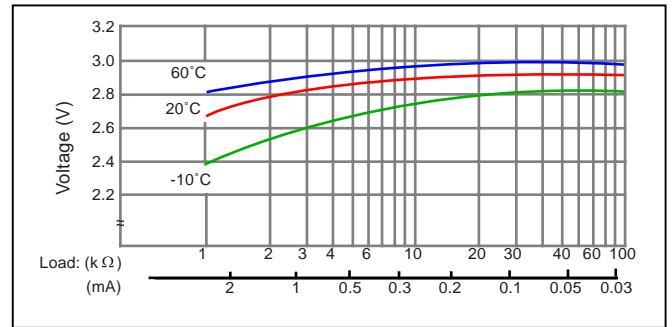

Capacity vs. load resistance

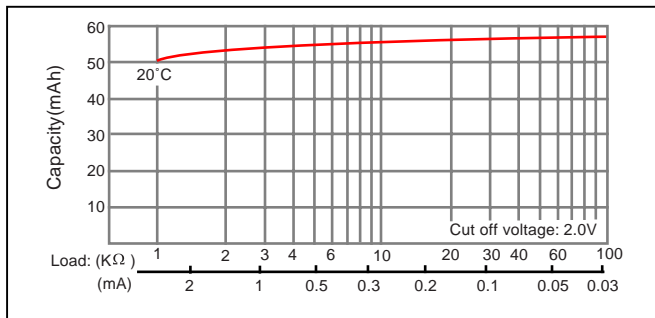

Capacity vs. load resistance

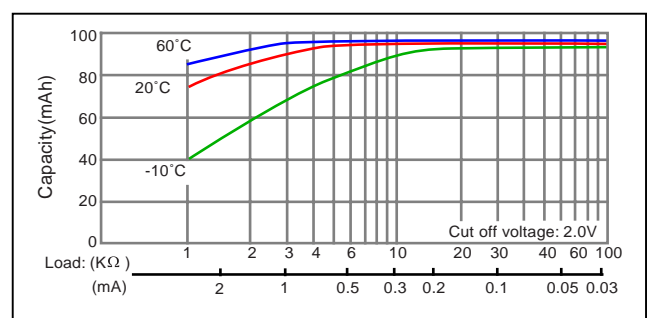

CR2025

CR2032

Discharge temperature characteristics

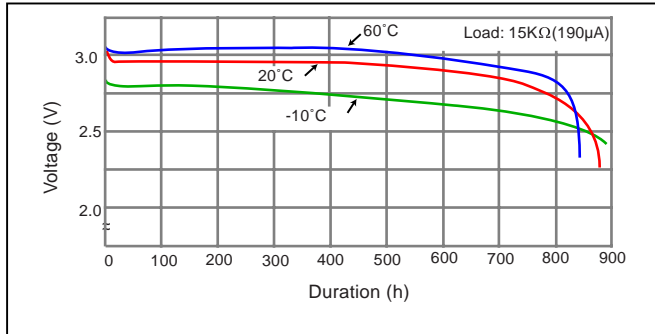

Discharge temperature characteristics

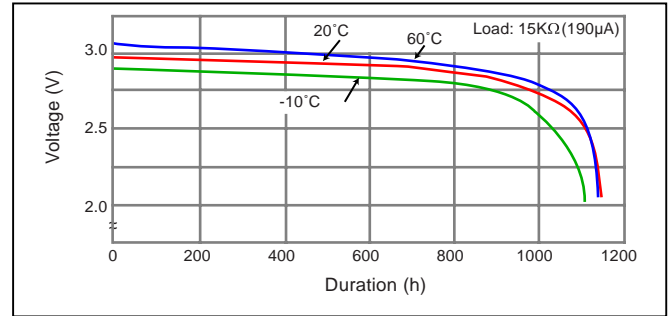

Operating voltage vs. load resistance

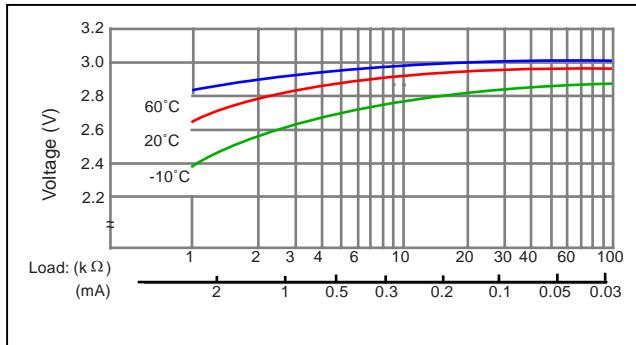

Operating voltage vs. load resistance

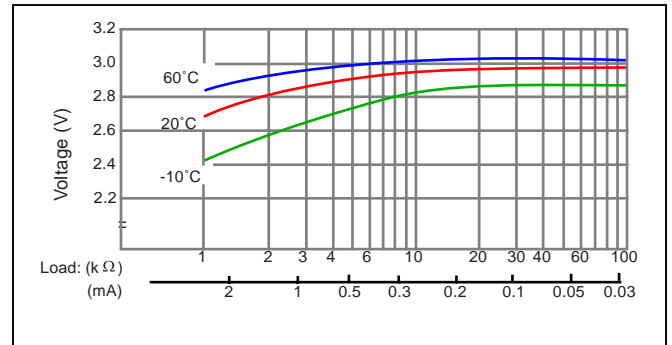

Capacity vs. load resistance

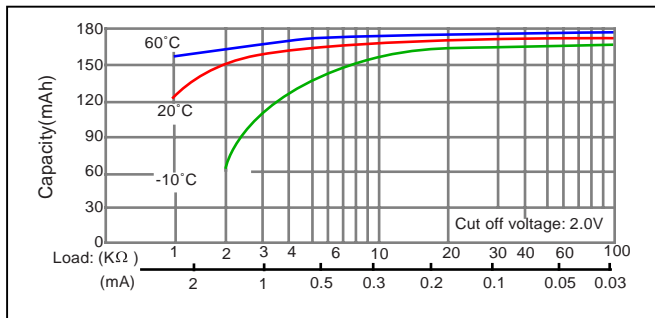

Capacity vs. load resistance

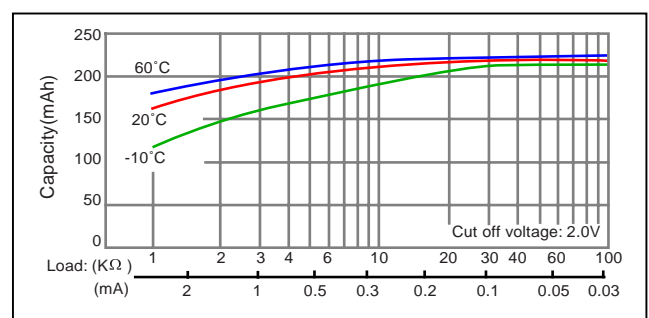

CR2320

CR2330

Discharge temperature characteristics

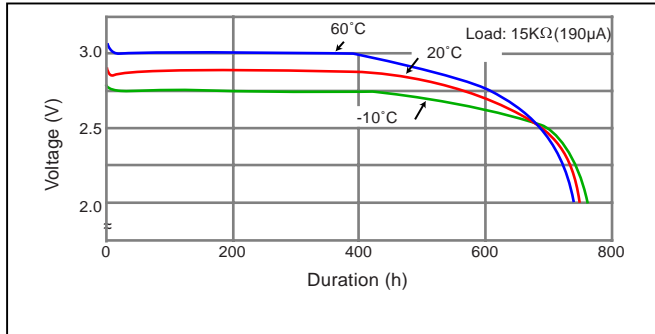

Discharge temperature characteristics

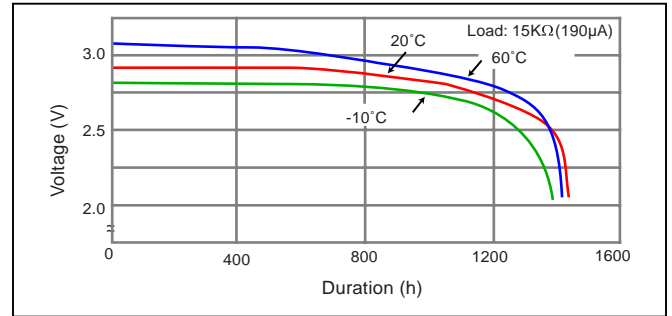

Operating voltage vs. load resistance

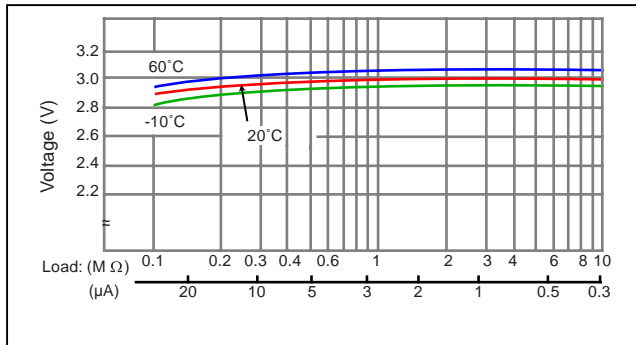

Operating voltage vs. load resistance

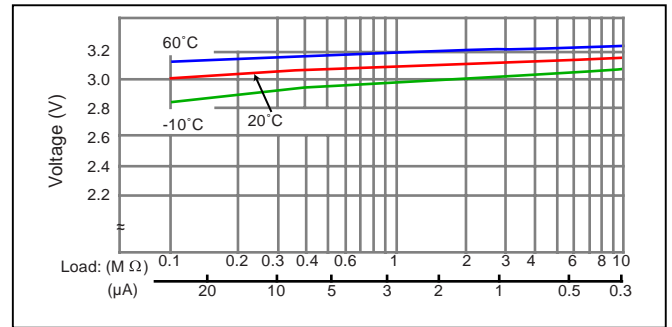

Capacity vs. load resistance

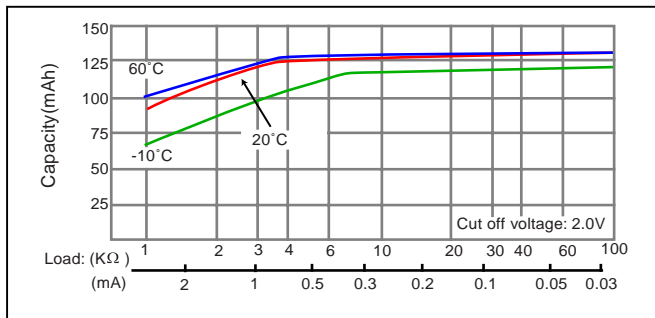

Capacity vs. load resistance

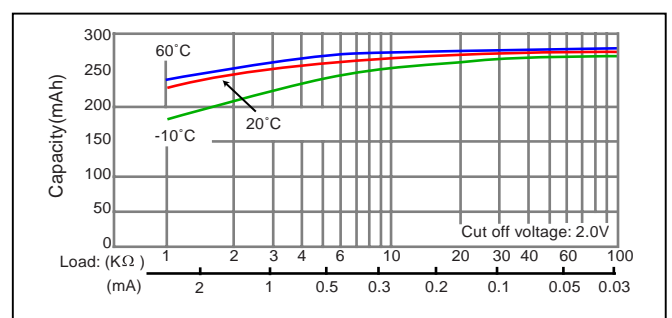

CR2354

CR2412

Discharge temperature characteristics

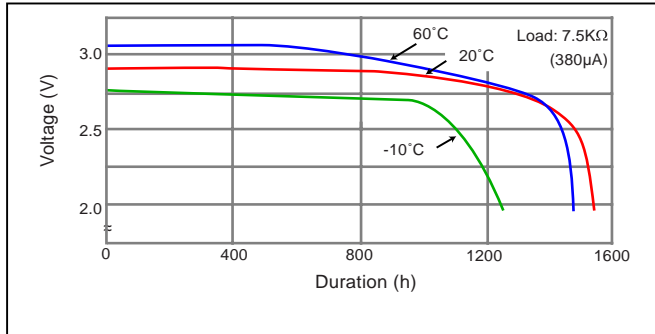

Discharge temperature characteristics

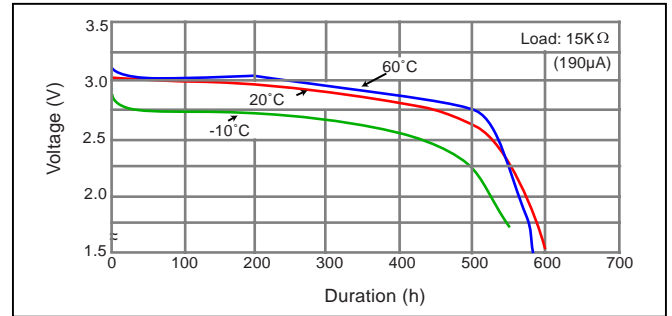

Operating voltage vs. load resistance

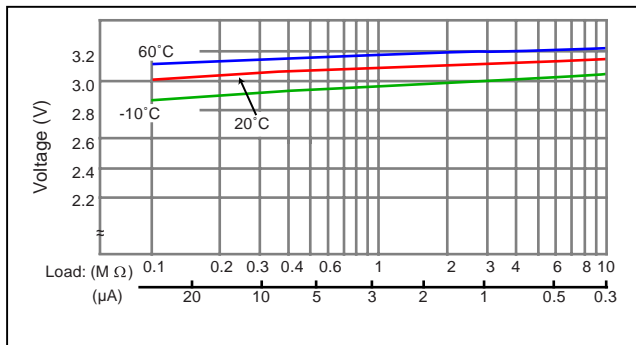

Operating voltage vs. load resistance

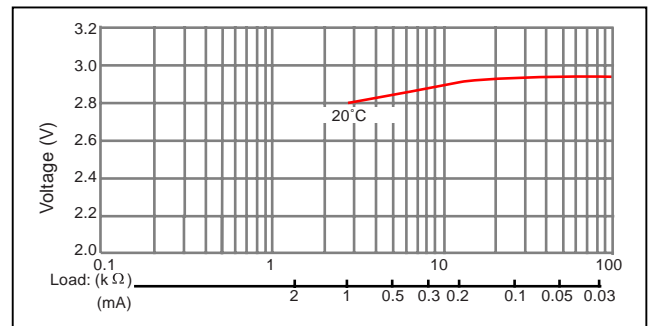

Capacity vs. load resistance

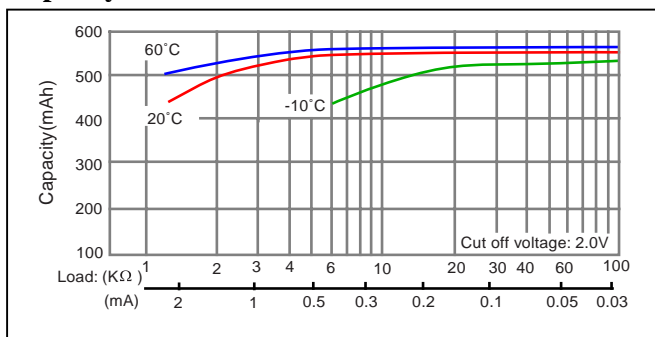

Capacity vs. load resistance

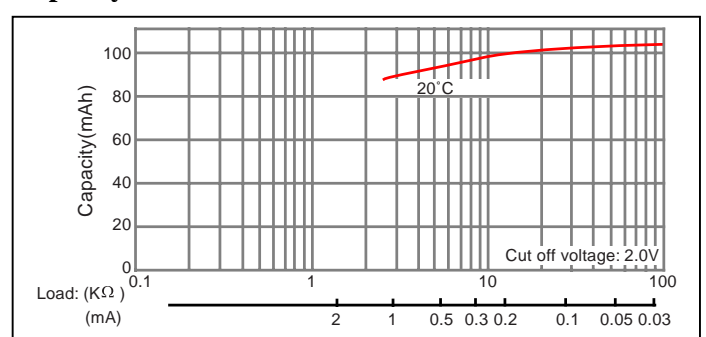

CR2477

CR3032

Discharge temperature characteristics

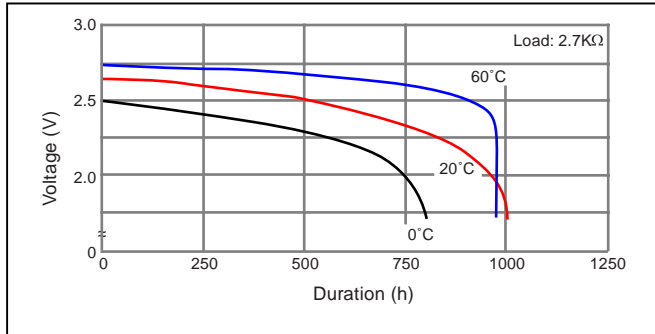

Discharge temperature characteristics

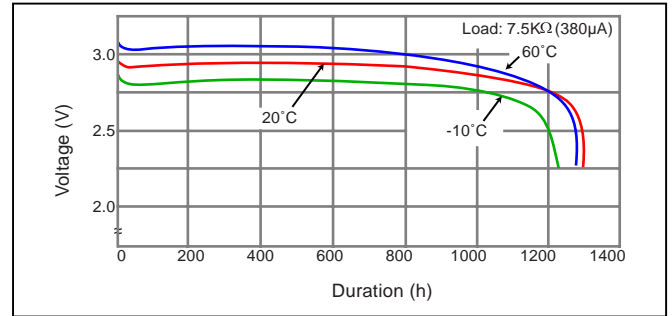

Operating voltage vs. load resistance

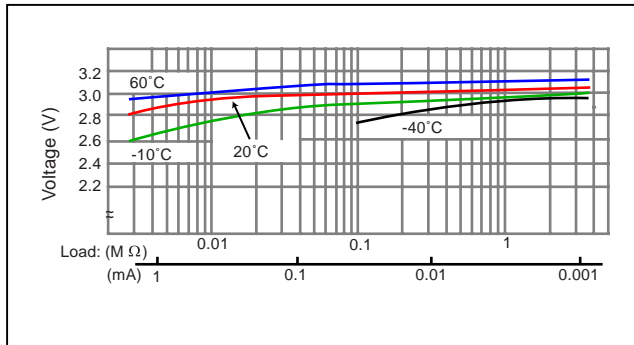

Operating voltage vs. load resistance

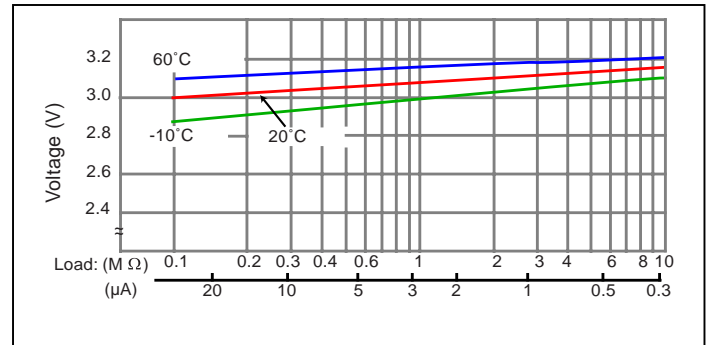

Capacity vs. load resistance

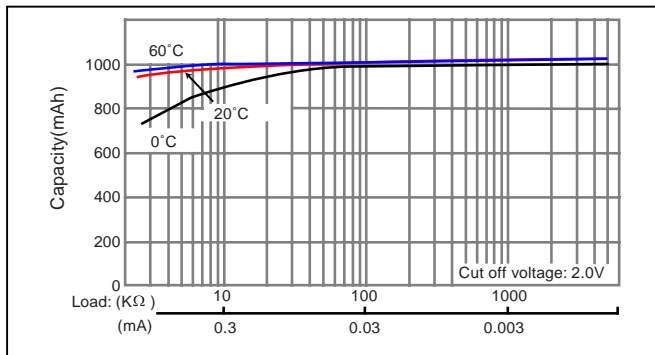

Capacity vs. load resistance

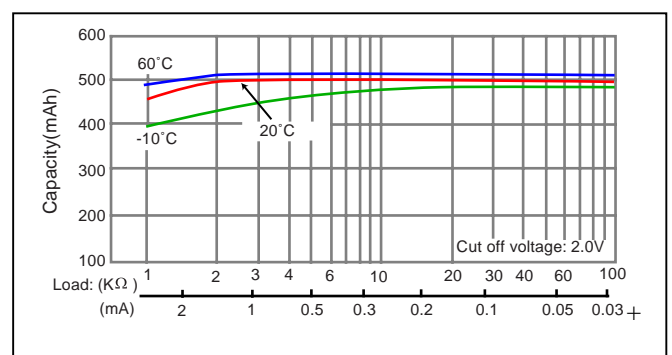

Coin type poly carbonmonofluoride (BR series "A" type) lithium batteries for high temperature usage

Overview

We have successfully extended the temperature limits at which coin type poly carbonmonofluoride lithium batteries can be used from the current 85°C to 150°C by replacing the material for the gaskets and separators employed in these coin type lithium batteries with a special engineering plastic and by incorporating an electrolyte with a high boiling point.

Features

- Wider operating temperature range**
 The polyolefin plastic used in the past as the material for the gaskets and separators has been replaced with a new special engineering plastic, and an electrolyte with a high boiling point has been adopted. These innovations have made it possible to use the new batteries at a temperature range extending from -40°C to 150°C (-40°C to 125°C with model BR2477A).
- Excellent storage properties with less self-deterioration**
 Since these batteries are made of lithium, their self-deterioration cannot be described as very low. However, the self-deterioration has been reduced by using chemically stable materials and excellent preparation and sealing technology. The self-deterioration rate over the course of one year at room temperature for Panasonic's coin type lithium batteries has thus been cut to approximately 0.5%. This makes it possible to meet the demand for a storage period of 10 or more years at room temperature.

- Outstanding resistance to electrolyte leakage**
 The organic electrolyte used for lithium batteries has very low creeping characteristics. The characteristics of this electrolyte and Panasonic's topnotch sealing technology combine to produce outstanding resistance to electrolyte leakage.
- Approved under UL standards**
 All of Panasonic's coin type lithium batteries have been approved by UL (Underwriters Laboratories Inc.) of the U.S.

Applications

- Back-up power supplies in office automation equipment, factory automation equipment, home electrical appliances, etc.
- Power supplies for automotive electrical parts
- Power supplies for meters

If the desired application requires continuous exposure to temperatures exceeding 120°C, please consult Panasonic in advance.

Cutaway view

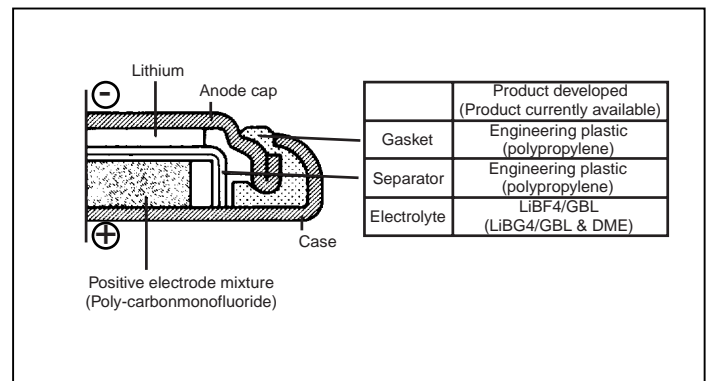

Specification Table

Model No.	JIS	IEC	Electrical characteristics 20°C			Dimensions (Max.)		Approx. weight (g)
			Nominal voltage (V)	Nominal capacity *1 (mAh)	Continuous drain	Diameter (mm)	Height (mm)	
					Standard (mA)			
BR1225A *2	---	---	3	48	0.03	12.5	2.50	0.8
BR1632A	---	---	3	120	0.03	16.0	3.20	1.5
BR2330A	---	---	3	255	0.03	23.0	3.00	3.2
BR2477A	---	---	3	1000	0.03	24.5	7.00	8.0

* 1 Nominal capacity shown above is based on standard drain and cut off voltage down to 2.0 V at 20°C

* 2 Under Development

Type	Model No.	P.V.C. Cover		Characteristics		BR, CR
		With P.V.C. cover	Without P.V.C. cover	Nominal Voltage (V)	Nominal capacity (mAh)	
H type	BR2477A/HB	⊗		3	1000	CR2477/1HF
	BR2477A/HC		⊗	3	1000	CR2477/1HE
	BR2330A/HA	⊗		3	255	CR2330/1HT
	BR2330A/HB		⊗	3	255	CR2330/1HT
	BR1632A/HA	⊗		3	120	CR1632/1HF
	BR1632A/HB		⊗	3	120	CR1632/1HE
V type	BR2477A/VA	⊗		3	1000	CR2477/1VC
	BR1632A/VA	⊗		3	120	BR1632/V1A
F type	BR1632A/FA	⊗		3	120	CR1632/1F2
Others	BR2330A/GA		⊗	3	255	CR2330/1GU

Characteristics

Storage Characteristics (100°C)

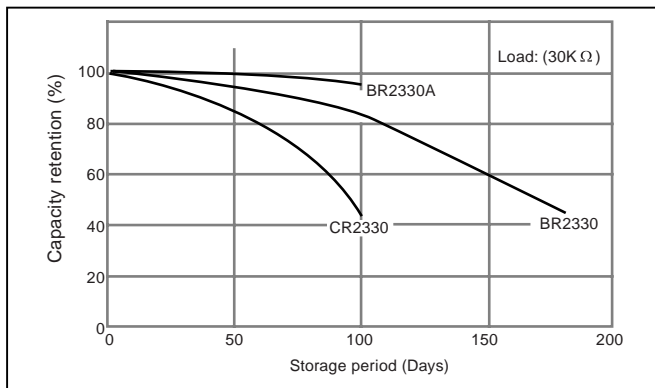

BR1225A

Discharge temperature characteristics-BR1225A

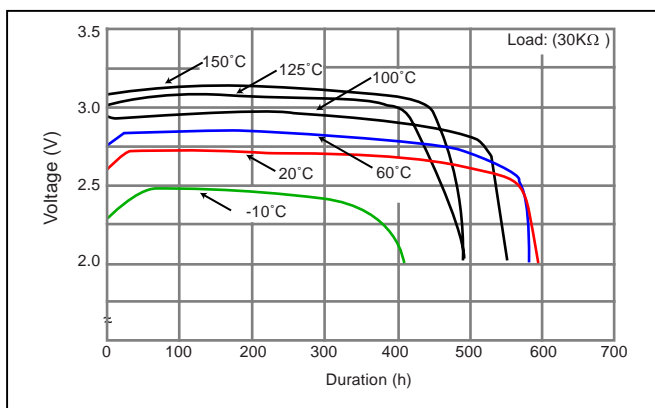

Storage Characteristics (100°C)

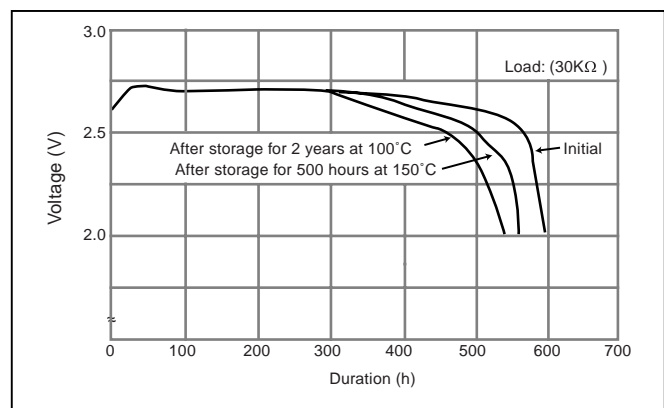

BR1632A

Discharge temperature characteristics

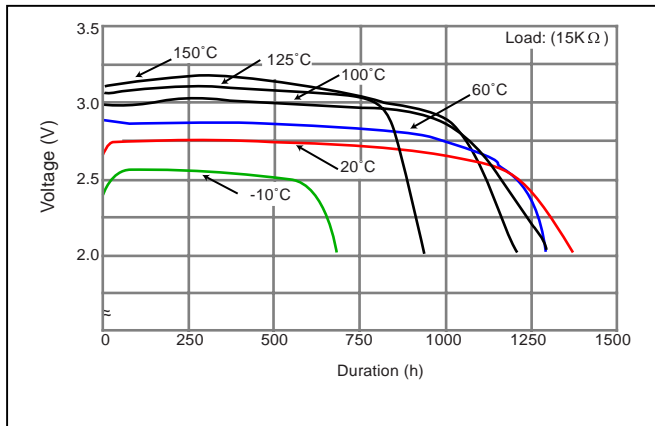

Storage Characteristics

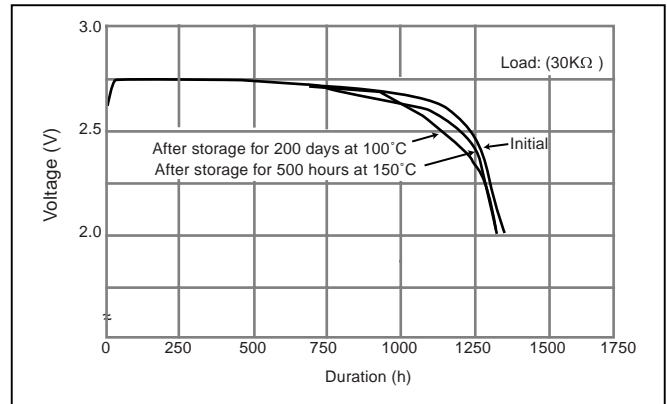

BR2330A

Discharge temperature characteristics

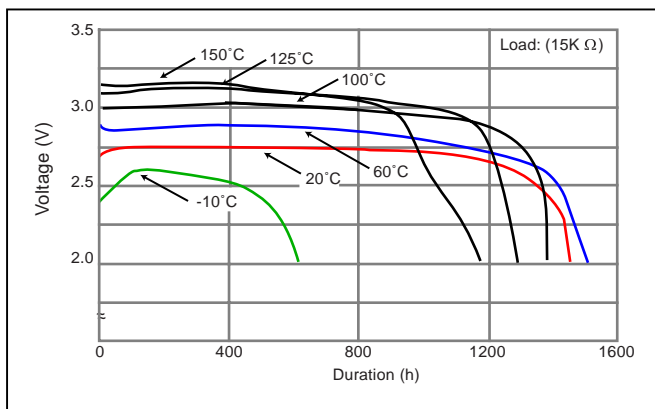

Storage Characteristics

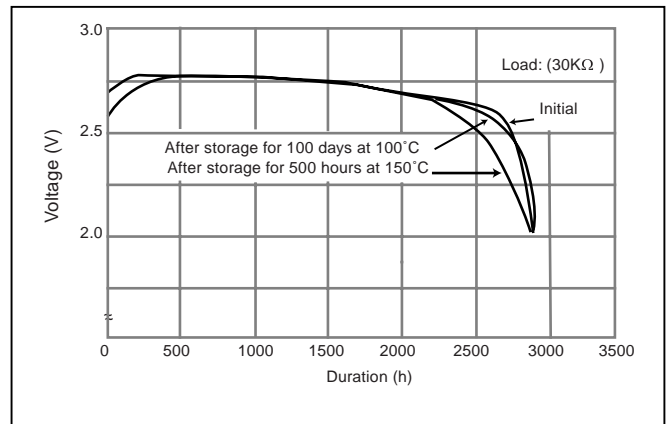

BR2477A

Discharge temperature characteristics

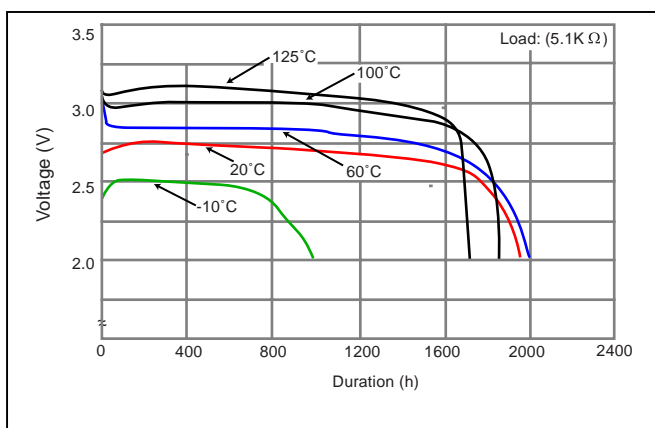

Storage Characteristics

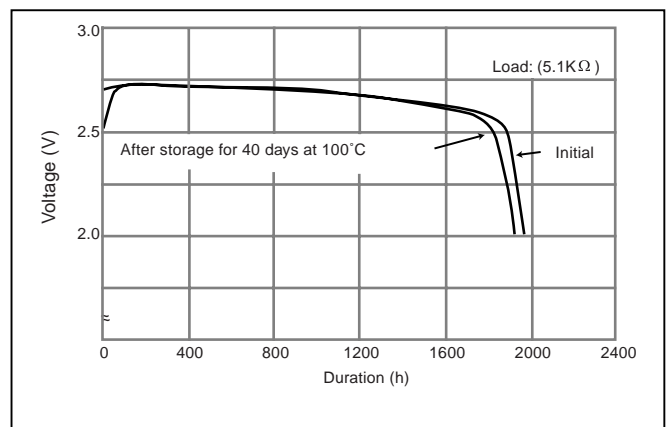

Precautions for handling coin type lithium batteries

Please observe the following precautions to keep batteries in good condition.

Precautions for storage

- Avoid storing batteries at unusually high or low temperatures.
- Store batteries in a low-humidity location with little temperature variation. If batteries are stored in a humid place, moisture may condense on them, exerting an adverse influence on their electrical characteristics.
- Keep batteries away from direct sunlight.

Handling precautions

- When measuring the battery voltage, use an instrument with an internal resistance of 10 M Ω or higher.
- Before loading batteries in equipment, check that the terminals are clean and not deformed; if dirty, clean and dry the terminals before loading batteries.
- Batteries of different types or grades have different characteristics even when they have the same size and shape. Carefully check the labels on batteries when replacing.
- Lithium batteries show a high voltage even when only a slight capacity is remaining, which can be misunderstood as having sufficient capacity available. When any one out of two or more batteries in use together is exhausted, replace all batteries at the same time, even if they still show a high voltage.
- When mounting batteries with terminals onto a printed circuit board, etc. by dipping in a soldering bath, limit the dipping time to 5 seconds or less; dipping for a longer time may exert an adverse influence on the electrical characteristics such as voltage and capacity. Use extreme caution not to drop batteries into the soldering bath during the dipping; if dropped, batteries may rupture due to abrupt heating. Avoid direct soldering to batteries. Also, do not use reflow soldering.
* For details, refer to "Guide to correct soldering of lithium batteries with terminals" on page 94.
- Avoid inserting batteries into antistatic materials or wrapping the board mounted with batteries in conductive sheets, which may cause a voltage drop or consumption of the capacity.
* For details, refer to "Use caution with antistatic conductive materials" on page 96.

- Do not put two or more batteries loosely in a bag or container; external shorting between batteries may cause voltage drop or consumption of the capacity.
* For details, refer to "Use caution in allowing batteries to contact each other" on page 97.
- When two or more batteries are used in series, inversion of polarity may occur in a battery near the end of its life. This indicates that the battery has become exhausted first. This is not an abnormal condition.
- If a voltage drop due to shorting, even momentarily, occurs in lithium batteries, it takes a period of time for the voltage to recover. In such a situation, use caution not to check the voltage of the battery before sufficient recovery time, or it may lead to a misjudgment that the battery is defective.

Precautions in equipment design

- For mounting batteries, avoid high-temperature locations and protect them from foreign materials.
- When a battery and another power source are to be used together in the equipment circuit, design the circuit so as not to allow a current from the other power source to flow into the battery.
- If lead wires and connection terminals such as tab terminals are needed for batteries, Panasonic can supply external terminals (connectors, etc.) on request.
- For the contact point on power supply terminals, use nickel-plated iron, nickel-plated stainless steel or higher grade materials.
- For ensuring stable contact, apply a contact pressure of 2N~10N (approx. 200~1000 gf).
* For details, refer to "Ensuring positive battery contact with equipment" on page 95.